

# FRIGIDAIRE

# User Manual

## FRG612SC



### CONTENTS

Safety information.....	2	Using the accessories.....	16
Safety instructions.....	4	Additional functions.....	18
Installation.....	8	Hints and tips.....	19
Product description.....	11	Care and cleaning.....	26
Before first use.....	12	Troubleshooting.....	29
Daily use.....	13	Technical data.....	31
Clock functions.....	15	.....	.....

## SAFETY INFORMATION

Before the installation and use of the appliance, carefully read the supplied instructions. The manufacturer is not responsible for any injuries or damage that are the result of incorrect installation or usage. Always keep the instructions in a safe and accessible location for future reference.

### **Children and vulnerable people safety**

- This appliance can be used by children aged from 8 years and above and persons with reduced physical, sensory or mental capabilities or lack of experience and knowledge if they have been given supervision or instruction concerning the use of the appliance in a safe way and understand the hazards involved.
- Children between 3 and 8 years of age and persons with very extensive and complex disabilities shall be kept away from the appliance unless continuously supervised.
- Children of less than 3 years of age should be kept away from the appliance unless continuously supervised.
- Do not let children play with the appliance.
- Keep all packaging away from children and dispose of it appropriately.
- Keep children and pets away from the appliance when it operates or when it cools down. Accessible parts may become hot during use.
- If the appliance has a child safety device, it should be activated.
- Children shall not carry out cleaning and user maintenance of the appliance without supervision.

### **General Safety**

- Only a qualified person must install this appliance and replace the cable.
- Do not use the appliance before installing it in the built-in structure.

## SAFETY INFORMATION

- Disconnect the appliance from the power supply before carrying out any maintenance.
- If the mains power supply cable is damaged, it must be replaced by the manufacturer, its Authorised Service Centre or similarly qualified persons to avoid an electrical hazard.
- **WARNING:** Ensure that the appliance is switched off before replacing the lamp to avoid the possibility of electric shock.
- **WARNING:** The appliance and its accessible parts become hot during use. Care should be taken to avoid touching heating elements.
- Always use oven gloves to remove or put in accessories or ovenware.
- To remove the shelf supports first pull the front of the shelf support and then the rear end away from the side walls. Install the shelf supports in the opposite sequence.
- Do not use a steam cleaner to clean the appliance.
- Do not use harsh abrasive cleaners or sharp metal scrapers to clean the glass door since they can scratch the surface, which may result in shattering of the glass.

# SAFETY INSTRUCTIONS

This appliance is suitable for the following markets: SA

## Installation

### WARNING!

Only a qualified person must install this appliance.

- Remove all the packaging.
- Do not install or use a damaged appliance.
- Follow the installation instructions supplied with the appliance.
- Always take care when moving the appliance as it is heavy. Always use safety gloves and enclosed footwear.
- Do not pull the appliance by the handle.
- Install the appliance in a safe and suitable place that meets installation requirements.
- Keep the minimum distance from other appliances and units.
- Before mounting the appliance, check if the oven door opens without restraint.
- Do not operate the appliance without the cavity bottom cover. It is a functional safety component.
- The appliance is equipped with an electric cooling system. It must be operated with the electric power supply.

Cabinet minimum height (Cabinet under the worktop minimum height)	590 (600) mm
---	--------------

Cabinet width	560 mm
---------------	--------

Cabinet depth	550 (550) mm
---------------	--------------

Height of the front of the appliance	594 mm
--------------------------------------	--------

Height of the back of the appliance	576 mm
-------------------------------------	--------

Width of the front of the appliance	595 mm
-------------------------------------	--------

Width of the back of the appliance	559 mm
------------------------------------	--------

Depth of the appliance	569 mm
------------------------	--------

Built in depth of the appliance	548 mm
---------------------------------	--------

Depth with open door	1022 mm
----------------------	---------

Ventilation opening minimum size. Opening placed on the bottom rear side	560x110 mm
--	------------

Ventilation opening minimum size. Opening placed on the upper rear side	560x50 mm
---	-----------

Mains supply cable length. Cable is placed in the right corner of the back side	1500 mm
---	---------

Mounting screws	4x25 mm
-----------------	---------

## Electrical connection

### WARNING!

Risk of fire and electric shock.

- All electrical connections should be made by a qualified electrician.
- The appliance must be earthed.
- Make sure that the parameters on the rating plate are compatible with the electrical ratings of the mains power supply.
- Always use a correctly installed shockproof socket.
- Do not use multi-plug adapters and extension cables.
- Make sure not to cause damage to the mains plug and to the mains cable. Should the mains cable need to be replaced, this must be carried out by our Authorised Service Centre.

# SAFETY INSTRUCTIONS

- Do not let mains cables touch or come near the appliance door or the niche below the appliance, especially when it operates or the door is hot.
- The shock protection of live and insulated parts must be fastened in such a way that it cannot be removed without tools.
- Connect the mains plug to the mains socket only at the end of the installation. Make sure that there is access to the mains plug after the installation.
- If the mains socket is loose, do not connect the mains plug.
- Do not pull the mains cable to disconnect the appliance. Always pull the mains plug.
- Use only correct isolation devices: line protecting cut-outs, fuses (screw type fuses removed from the holder), earth leakage trips and contactors.
- The electrical installation must have an isolation device which lets you disconnect the appliance from the mains at all poles. The isolation device must have a contact opening width of minimum 3 mm.
- This appliance is supplied only with a main cable.

## CABLE TYPES APPLICABLE FOR INSTALLATION OR REPLACEMENT FOR EUROPE:

H05 V2V2-F (T90), H05 BB-F

For the section of the cable refer to the total power on the rating plate. You can also refer to the table:

TOTAL POWER (W)	SECTION OF THE CABLE (MM <sup>2</sup> )
maximum 1380	3 x 0.75
maximum 2300	3 x 1
maximum 3680	3 x 1.5

The earth cord (green / yellow cable) must be 2 cm longer than phase and neutral cables (blue and brown cables).

## Gas connection

- All gas connections must be made by a qualified person.
- Before installation, make sure that the local distribution conditions (nature of the gas and gas pressure) and the adjustment of the appliance are compatible.
- Make sure that there is air circulation around the appliance.
- The information about the gas supply is on the rating plate.
- This appliance is not connected to a device, which evacuates the products of combustion. Make sure to connect the appliance according to current installation regulations. Follow the requirements for adequate ventilation.

## Use

### WARNING!

Risk of injury, burns and electric shock or explosion.

- This appliance is for household (indoors) use only.
- Do not change the specification of this appliance.
- Make sure that the ventilation openings are not blocked.
- Do not let the appliance stay unattended during operation.
- Deactivate the appliance after each use.
- Be careful when you open the appliance door while the appliance is in operation. Hot air can release.
- Do not operate the appliance with wet hands or when it has contact with water.
- Do not apply pressure on the open door.
- Do not use the appliance as a work surface or as a storage surface.

# SAFETY INSTRUCTIONS

- Open the appliance door carefully. The use of ingredients with alcohol can cause a mixture of alcohol and air.
- Do not let sparks or open flames to come in contact with the appliance when you open the door.
- Do not put flammable products or items that are wet with flammable products in, near or on the appliance.

## WARNING!

Risk of damage to the appliance.

- To prevent damage or discoloration to the enamel:
  - do not put aluminium foil directly on the bottom of cavity of the appliance.
  - do not put water directly into the hot appliance.
  - do not keep moist dishes and food in the appliance after you finish the cooking.
  - be careful when you remove or install the accessories.
- Discoloration of the enamel or stainless steel has no effect on the performance of the appliance.
- Use a deep pan for moist cakes. Fruit juices cause stains that can be permanent.
- This appliance is for cooking purposes only. It must not be used for other purposes, for example room heating.
- Always cook with the oven door closed.
- If the appliance is installed behind a furniture panel (e.g. a door) make sure the door is never closed when the appliance operates. Heat and moisture can build up behind a closed furniture panel and cause subsequent damage to the appliance, the housing unit or the floor. Do not close the furniture panel until the appliance has cooled down completely after use.

## Care and cleaning

### WARNING!

Risk of injury, fire, or damage to the appliance.

- Before maintenance, deactivate the appliance and disconnect the mains plug from the mains socket.
- Make sure the appliance is cold. There is the risk that the glass panels can break.
- Replace immediately the door glass panels when they are damaged. Contact the Authorised Service Centre.
- Be careful when you remove the door from the appliance. The door is heavy!
- Clean regularly the appliance to prevent the deterioration of the surface material.
- Clean the appliance with a moist soft cloth. Use only neutral detergents. Do not use abrasive products, abrasive cleaning pads, solvents or metal objects.
- If you use an oven spray, follow the safety instructions on its packaging.

## Internal lighting

### WARNING!

Risk of electric shock.

- Concerning the lamp(s) inside this product and spare part lamps sold separately: These lamps are intended to withstand extreme physical conditions in household appliances, such as temperature, vibration, humidity, or are intended to signal information about the operational status of the appliance. They are not intended to be used in other applications and are not suitable for household room illumination.
- This product contains a light source of energy efficiency class G.
- Use only lamps with the same specifications.

## Service

- To repair the appliance contact the Authorised Service Centre.
- Use original spare parts only.

## Disposal

### **WARNING!**

Risk of injury or suffocation.

- Contact your municipal authority for information on how to dispose of the appliance.
- Disconnect the appliance from the mains supply.
- Cut off the mains electrical cable close to the appliance and dispose of it.
- Flat the external gas pipes.

# INSTALLATION

## ⚠ WARNING!

Refer to Safety chapters.

### Gas connection

The gas supply ramp is on the back of the oven.

1. Before the gas connection, disconnect the oven from the mains.
2. Close the primary valve of the gas supply.
3. Do not fully put the oven into the built-in cabinet, leave approximately 30 cm gap.
4. Connect gas supply.

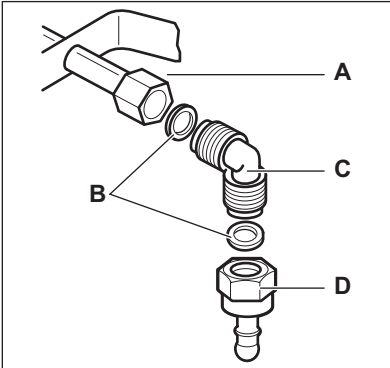

- A. End of shaft with nut
  - B. Washer
  - C. Elbow
  - D. Rubber pipe holder for liquid gas
5. Put the supplied gasket between the pipe and the gas supply ramp. Turn the pipe to the 1/2" gas supply ramp.
  6. Use a 22 mm spanner to tighten the nuts. Keep the gas supply ramp in the correct position. Gently handle the gas supply circuit.

## ⚠ WARNING!

Do not use flame to check for leaks.

7. Fully move the oven into the built-in cabinet.

## ⚠ WARNING!

Do not squeeze the gas supply ramp and the pipe when you move the oven into the built-in cabinet.

8. Seal the connection correctly. Use a leak detection to control it. Use the rubber pipe holder for liquid gas. Always engage the gasket. Then continue with the gas connection.

If one or more defects are visible, do not repair the pipe, but replace it.

When installation is complete, make sure that the seal of each pipe fitting is correct. Use a soapy solution, not flame.

### BEFORE THE APPLICATION CHECK IF THE FLEXIBLE PIPE:

Is at the room temperature.

Is no longer than 1500 mm.

Has no throttles.

Is not subject to traction or torsion.

Does not touch sharp edges or corners.

It is easily accessible.

### REGULARLY CONTROL THE FLEXIBLE PIPE. CHECK IF:

It is not cracked, cut, burnt on the two ends and on its full length.

It is not hardened, it should be elastic.

The fastening clamps are not rusted.

Expiration term is not due.

### Minimum level adjustment of the oven burner

1. Disconnect the oven from the mains.
2. Turn the knob for the gas control to the minimum position and remove it.
3. Adjust the adjustment screw (A) with a thin-bladed screwdriver.



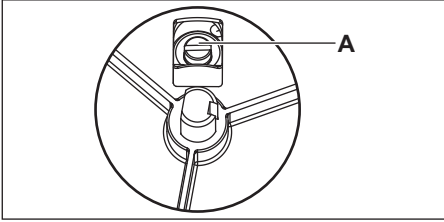

4. Attach the knob for the gas control.
5. Connect the oven to the mains.

## **⚠ WARNING!**

Only put the mains plug into the mains socket when all parts are back into their initial position. There is a risk of injury.

6. Light the gas oven burner.  
Refer to "Daily use" chapter.
7. Set the knob for the gas control to the maximum position and let the oven heat for at least 10 minutes.

8. Turn the knob for the gas control from the maximum to the minimum position. Control the flame. If the flame goes out, do the procedure again. There must be a small regular flame on the oven burner crown.

**The manufacturer objects liability if you do not obey to this safety measures.**

## **Building In**

Only set up the appliance in a kitchen or in a kitchen-dining room. Do not set up the appliance in a bathroom or a bedroom.

You can install the appliance "built-in" or "built-under". The dimensions of the built-in cabinet must agree with the related illustrations.

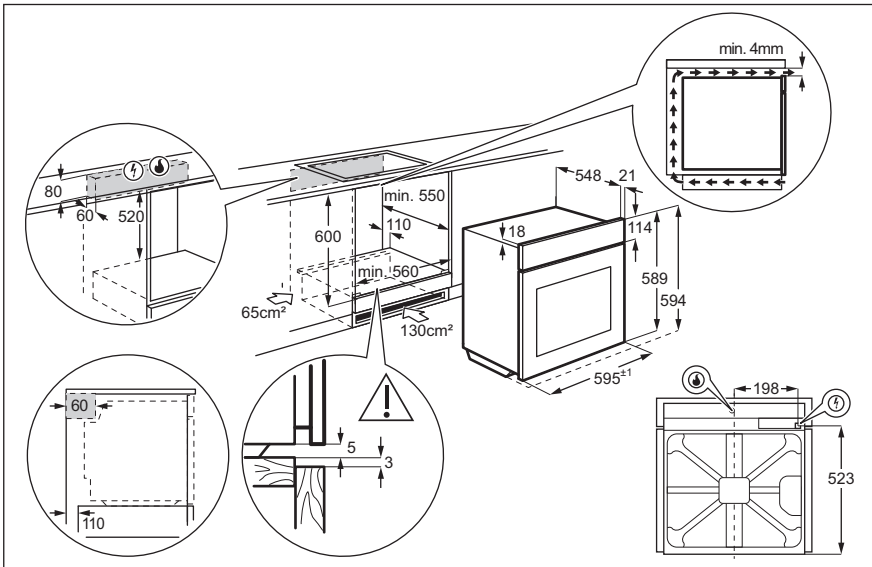

# INSTALLATION

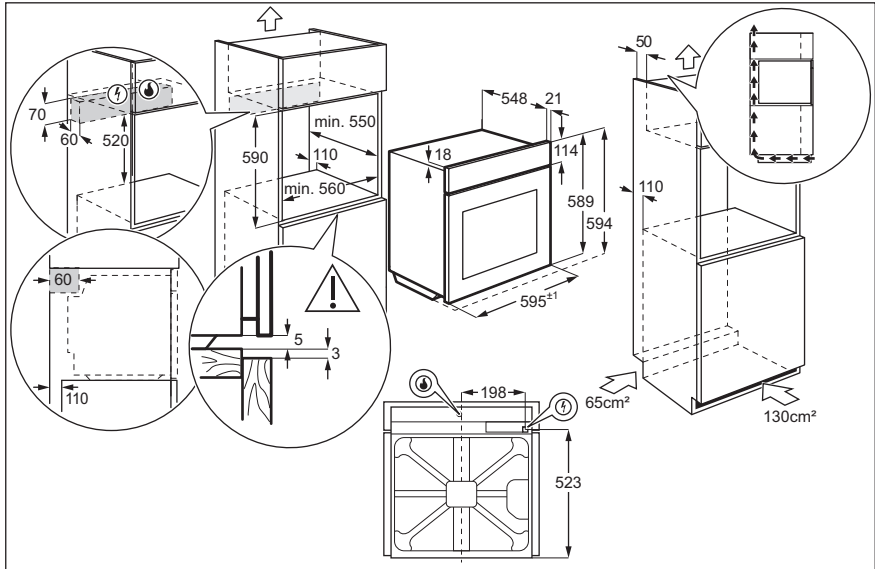

There must be a clearance of minimum 4 mm between the top surface of the appliance and the inner top of the cabinet.

When you install the appliance "built-under" (below a hob), install the hob before the oven unit.

The materials must be resistant to a temperature increase of minimum 60 °C above the ambient temperature.

There must be a continuous air supply around the oven in order to not have the oven become too hot.

For correct operation, the oven cabinet must have a minimum opening of 130 cm<sup>2</sup> in the front or on the sides (a minimum of 65 cm<sup>2</sup> for each side). The manufacturer recommends a 130 cm<sup>2</sup> opening in the front for a brick cabinet and a 65 cm<sup>2</sup> opening for each side for a wooden cabinet.

When you install a hob above the oven, make different electrical connections for the hob and for the oven.

Only make connections with correct cables for the power supplied.



Make sure that after the installation there is easy access to the appliance if repairs or maintenance are necessary.

## Securing the oven to the cabinet

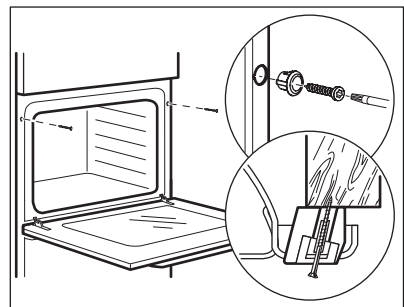

## General overview

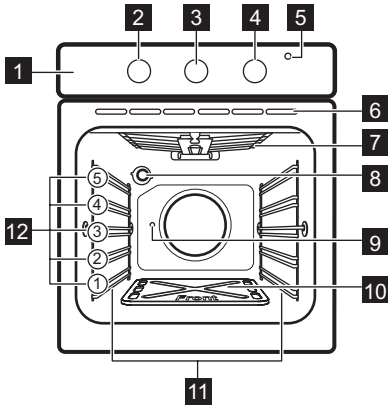

- 1 Control panel
- 2 Knob for the heating functions
- 3 Knob for the Minute Minder
- 4 Knob for the gas control
- 5 Power indicator
- 6 Air vents for the cooling fan
- 7 Heating element
- 8 Lamp
- 9 Turnspit hole
- 10 Oven cavity bottom plate
- 11 Shelf support, removable
- 12 Shelf positions

## Accessories

- **Wire shelf**  
For cookware, cake tins, roasts.
- **Baking tray**  
For cakes and biscuits.
- **Turnspit**  
For roasting larger joints of meat and poultry.

# BEFORE FIRST USE

## WARNING!

Refer to Safety chapters.

## Oven cavity bottom plate

When you buy the appliance, at first the oven cavity bottom plate is positioned on the accessories. Before you use the appliance for the first time, place the bottom plate on the burner area, as shown in the "Product description" chapter.

## Initial Cleaning

Remove all accessories and removable shelf supports from the oven.



Refer to "Care and cleaning" chapter.

Clean the oven and the accessories before first use.

Put the accessories and the removable shelf supports back to their initial position.

## Preheating

Preheat the empty appliance before first use.

1. Set the maximum temperature.
2. Let the appliance operate for 1 hour.
3. Set the function .
4. Let the appliance operate for 15 minutes.



Accessories can become hotter than usual. The appliance can emit an odour and smoke. This is normal. Make sure that the airflow is sufficient.

Let the oven cool down. Dampen a soft cloth with warm water and a little mild washing-up liquid and use this to clean the oven cavity.

**⚠ WARNING!**

Refer to Safety chapters.



**Oven functions**

OVEN FUNCTION	APPLICATION	
0	Off position	The oven is off.
	Light	To turn on the lamp without a cooking function.
	Turnspit	To roast larger pieces of meat on the spit rod.

**Power indicator**

The power indicator comes on when you turn the knob for the oven functions.

**Knob for the gas control**

SYMBOL	FUNCTION
 Conventional Cooking	Heat from the bottom of the oven. Range of temperature adjustment (150 °C - 250 °C).
 Grill	Heats from the top.

**Ignition of oven gas burner****Oven safety device:**

The gas oven has a thermocouple. It stops the gas flow if the flame goes out.

1. Press the knob for the gas control and turn it to .
2. Keep the knob for the gas control pushed for 15 seconds or less to let the thermocouple warm up. Do not release

the knob until the flame ignites, otherwise the gas flow is interrupted. Do not keep the knob for the gas control pushed for more than 15 seconds. If the oven burner does not ignite after 15 seconds, release the knob for the gas control, turn it into off position, open the oven door. Wait minimum 1 minute, close the oven door and try to ignite the oven burner again.

**After igniting the oven gas burner**

1. Release the knob for the gas control.

## DAILY USE

2. Turn the knob for the gas control to set the necessary heat setting.

Control the flame through the holes in the bottom of the oven.

### Using the grill



#### Oven safety device:

The gas oven has a thermocouple. It stops the gas flow if the flame goes out.

1. Press the knob for the gas control and turn it to . Keep the knob for the gas control pushed for 15 seconds or less. Do not release the knob until the flame ignites.
2. Release the knob for the gas control. Do not keep the knob for the gas control pushed for more than 15 seconds. If the grill burner does not ignite after 15 seconds, release the knob for the gas control, turn it into off position, open the oven door. Wait minimum 1 minute, close the oven door and try to ignite the grill burner again.

Refer to "Hints and Tips" chapter, Grilling.

### Minute Minder

Use it to set a countdown time for an oven function.



This function has no effect on the operation of the appliance.

Turn the knob for the timer as far as it goes, then turn it to necessary time period. After the time period is completed, an acoustic signal sounds.

## USING THE ACCESSORIES

### **⚠ WARNING!**

Refer to Safety chapters.

### Using the turnspit

### **⚠ WARNING!**

Be careful when you use the turnspit. The forks and the spit are sharp. There is a risk of injury.

### **⚠ WARNING!**

Use oven gloves when you remove the turnspit. The turnspit and the grill are hot. There is a risk of burns.

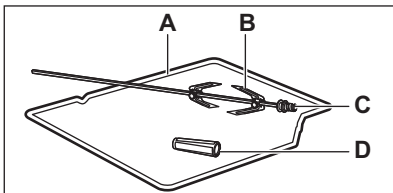

- A. Turnspit frame
- B. Forks
- C. Spit
- D. Handle

1. Put the turnspit handle into the spit.
2. Put the deep pan on the lowest shelf position.
3. Put the spit frame on the third shelf position from the bottom.

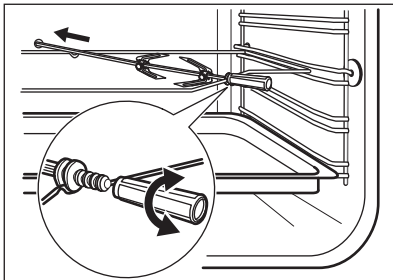

4. Install the first fork on the spit, then put the meat on the turnspit and install the second fork.

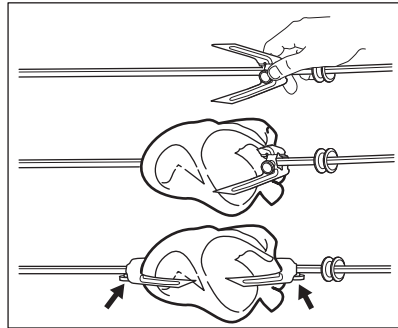

5. Use the screws to tighten the forks.
6. Put the tip of the spit into the turnspit hole.
7. Lay the back side of the spit on the turnspit frame. Refer to "Product description" chapter.
8. Remove the turnspit handle.
9. Select a function with the turnspit position. The turnspit rotates.
10. Ignite the grill burner. Refer to the cooking tables.

### Inserting the accessories

Wire shelf:

Push the shelf between the guide bars of the shelf support and make sure that the feet point down.

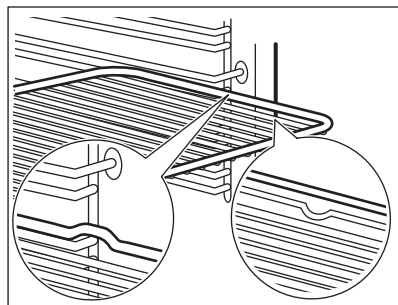

Baking tray:

Push the baking tray between the guide bars of the shelf support.



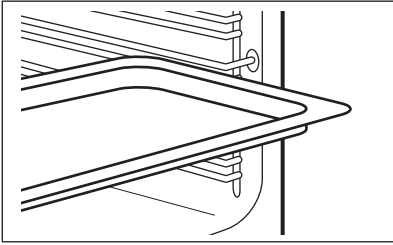

Wire shelf and baking tray together:

Push the baking tray between the guide bars of the shelf support and the wire shelf on the guide bars above.

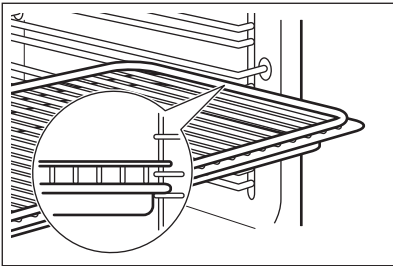

Small indentation at the top increase safety. The indentations are also anti-tip devices. The high rim around the shelf prevents cookware from slipping of the shelf.

## ADDITIONAL FUNCTIONS

### **Cooling fan**

When the oven operates, the cooling fan turns on automatically to keep the surfaces of the oven cool. If you turn off the oven, the cooling fan can continue to operate until the oven cools down.

## **⚠ WARNING!**

Refer to Safety chapters.



The temperature and baking times in the tables are guidelines only. They depend on the recipes and the quality and quantity of the ingredients used.

## **Cooking recommendations**

The oven has five shelf positions.

Count the shelf positions from the bottom of the oven floor.

Your oven may bake or roast differently to the oven you had before. The below tables provide you with the standard settings for temperature, cooking time and shelf position.

If you cannot find the settings for a special recipe, look for the similar one.

### **Baking cakes**

Do not open the oven door before 3/4 of the set cooking time is up.

### **Cooking meat and fish**

Leave the meat for approximately 15 minutes before carving so that the juice does not seep out.

To prevent too much smoke in the oven during roasting, add some water into the deep pan. To prevent the smoke condensation, add water each time after it dries up.

## **Cooking tables**

Casseroles!

Preheat the empty oven before cooking.

Prepare 1.5 - 2.5 kg of food.

Use the fourth shelf position.

FOOD	TEMPERATURE (°C)	TIME (MIN)
Lasagne	180	45 - 50
Cannelloni	180	45 - 50
Potato gratin	180	33 - 40
Baked macaroni	180	45 - 50
Kebab Hala	190	35 - 40

Meat

Preheat the empty oven before cooking.

Use the third shelf position.

FOOD	TEMPERATURE (°C)	TIME (MIN)
Mutton, 1.7 kg	180 - 200	80 - 100
Chicken, 1 - 1.8 kg	220 - 230	80 - 90
Duck, 1.8 - 2.5 kg	220 - 230	100 - 120
Goose, 2.5 - 3.5 kg	220 - 230	160 - 180
Rabbit, 2 kg	180 - 190	60 - 80
Goat meat, 1.8 kg	170 - 180	60 - 90

Pizza

Preheat the empty oven before cooking.

Prepare 1.4 - 1.5 kg of food.

Use the third or fourth shelf position.

FOOD	TEMPERATURE (°C)	TIME (MIN)
Pizza, thin	200 - 210	20 - 30
Pizza, thick	200 - 210	25 - 30
Calzone	190 - 200	25 - 30

## HINTS AND TIPS

### Cakes

Preheat the empty oven before cooking.

FOOD	SHELF POSITION	TEMPERATURE (°C)	TIME (MIN)
Flat cake, 0.6 - 1.0 kg	4	170 - 180	20 - 30
Sponge cake, 1.0 - 1.5 kg	4	170 - 180	40 - 50
Feteer meshaltet, 1.2 - 1.5 kg	3 or 4	190	40 - 45

### Grilling

Preheat the empty oven for 3 minutes.

Use the fourth shelf position.

### Meat & Poultry

FOOD	QUANTITY (KG)	TEMPERATURE (°C)	TIME (MIN)	SHELF POSITION	COMMENTS
Beef with bone	1	min.	50 - 65	3	On the wire shelf. Put a deep pan on the second shelf position.
Beef without bone	1	190	55 - 65	3	On the wire shelf. Put a deep pan on the second shelf position.
Lamb	1	min.	50 - 65	3	On the wire shelf. Put a deep pan on the second shelf position.

Maximum temperature is the default value for all types of food.

FOOD	QUANTITY (KG)	TIME (MIN)
Burgers	0.6 (6 pieces)	20 - 30
Toast browning	0.5	9 - 12
Toast Hawai	6 pieces	7 - 14

### Gas oven cooking



The time does not include preheating. Always preheat the empty oven for 10 minutes.

## HINTS AND TIPS

FOOD	QUANTITY (KG)	TEMPERATURE (°C)	TIME (MIN)	SHELF POSITION	COMMENTS
Chicken / Rabbit	1,2	220 - 230	85 - 95	3	On the wire shelf. Put a deep pan on the second shelf position.
Duck	1	190	90 - 100	3	On the wire shelf. Put a deep pan on the second shelf position.
Turkey	4,5 - 5,5	160	220 - 250	2	In a deep pan.
Baked vegetables	1	160	-	3	Varies according to the vegetable.
Pastry					
FOOD	QUANTITY (KG)	TEMPERATURE (°C)	TIME (MIN)	SHELF POSITION	COMMENTS
Fruit tart	-	165	50 - 60	4	In a 26 cm round mould on the wire shelf
Fruit pie	-	min.	50 - 60	4	In a 26 cm round mould on the wire shelf
Sausage rolls	-	180	30 - 40	4	In an aluminium baking tray
Choux pastry	-	190	35 - 45	4	In an aluminium baking tray

## HINTS AND TIPS

FOOD	QUANTITY (KG)	TEMPERATURE (°C)	TIME (MIN)	SHELF POSITION	COMMENTS
Vol au vents	-	170	25 - 35	4	In an aluminium baking tray
Jam tarts	-	165	50 - 60	4	In a 30 cm round mould on the wire shelf

### Puddings

FOOD	QUANTITY (KG)	TEMPERATURE (°C)	TIME (MIN)	SHELF POSITION	COMMENTS
Egg Custard in a Bain Marie	-	min.	70 - 85	3	9 ceramic glasses in a deep pan with 2 cm of water

### Cakes

FOOD	QUANTITY (KG)	TEMPERATURE (°C)	TIME (MIN)	SHELF POSITION	COMMENTS
Rich fruit cake	-	min.	160 - 170	4	In a 20 cm mould on the wire shelf
Plain fruit cake	-	min.	160 - 170	4	In a 20 cm mould on the wire shelf
Madeira	-	min.	115 - 130	4	In a 20 cm mould on the wire shelf
Small cake	-	min. - 170	40 - 65	4	In an aluminium baking tray
Ginger bread	-	min.	45 - 55	4	In an aluminium baking tray

### Bread

FOOD	QUANTITY (KG)	TEMPERATURE (°C)	TIME (MIN)	SHELF POSITION	COMMENTS
Bread loaves	0,5	180 - 190	50 - 60	4	In an aluminium baking tray
Bread loaves	1	180 - 190	60 - 70	4	In an aluminium baking tray
Rolls and buns	-	180 - 190	25 - 35	4	In an aluminium baking tray

### Grilling



Preheat the empty oven for 3 minutes before cooking.

FOOD	QUANTITY		TIME (MIN)		SHELF POSITION
	PIECES	(G)	1ST SIDE	2ND SIDE	
Fillet steaks	4	800	13 - 15	13 - 15	4
Beef steaks	4	600	12 - 15	12 - 15	4
Sausages	8	-	12 - 15	12 - 15	4
Chicken (cut in 2)	2	1000	35 - 40	30 - 35	4
Kebabs	4	-	15 - 20	12 - 15	4
Breast of chicken	4	400	13 - 15	13 - 15	4
Fish fillet	4	400	13 - 15	12 - 14	4
Toasted sandwiches	4 - 6	-	5 - 7	-	4
Toast	4 - 6	-	2 - 4	2 - 3	4

### Turnspit

Use the turnspit with the bottom oven burner.

## HINTS AND TIPS



Preheat the empty oven for 10 minutes before cooking.

FOOD	QUANTITY (G)	TEMPERATURE (°C)	TIME (MIN)	SHELF POSITION
Poultry	1000 - 1200	190 - 200	75 - 85	3
Roasts	800 - 1000	190 - 200	75 - 85	3

### Information for test institutes

Tests according to IEC 60350-1.

FOOD	FUNCTION	ACCESSORIES	SHELF POSITION	TEMPERATURE (°C)	TIME (MIN)	COMMENTS
Small cake	Conventional Cooking	Aluminized baking tray	4	150 - 170	35 - 55	Put 20 small cakes per one baking tray. Preheat the oven for 10 minutes.
Apple pie	Conventional Cooking	Wire shelf	4	170	80 - 90	Use 2 tins (20 cm diameter), diagonally shifted. Preheat the oven for 10 minutes.
Sponge cake	Conventional Cooking	Wire shelf	4	170	50 - 60	Use a cake mould (26 cm diameter). Preheat the oven for 10 minutes.
Short bread	Conventional Cooking	Aluminized baking tray	4	160 - 170	25 - 40	Preheat the oven for 10 minutes.
Toast 4 - 6 pieces	Grill	Wire shelf	4	max.	2 - 3 minutes first side; 2 - 3 minutes second side	Preheat the oven for 3 minutes.



## HINTS AND TIPS

FOOD	FUNCTION	ACCESSORIES	SHELF POSITION	TEMPERATURE (°C)	TIME (MIN)	COMMENTS
Beef burger 6 pieces, 0.6 kg	Grill	Wire shelf and dripping pan	4	max.	20 - 30	Put the wire shelf on the fourth level and the dripping pan on the third level of the oven. Turn the food half-way through the cooking time. Preheat the oven for 3 minutes.

# CARE AND CLEANING

## **⚠ WARNING!**

Refer to Safety chapters.

## **Notes on cleaning**

Clean the front of the oven with a soft cloth with warm water and a mild cleaning agent.

To clean metal surfaces, use a dedicated cleaning agent.

Clean the oven interior after each use. Fat accumulation or other food remains may result in a fire.

Clean all accessories after each use and let them dry. Use a soft cloth with warm water and a cleaning agent.

Clean stubborn dirt with a special oven cleaner.

If you have nonstick accessories, do not clean them using aggressive agents, sharp-edged objects or a dishwasher. It can cause damage to the nonstick coating.

Moisture can condense in the oven or on the door glass panels. To decrease the condensation, operate the oven for 10 minutes before cooking. Clean the moisture from the cavity after each use.

## **Stainless steel or aluminium ovens**

Clean the oven door with a damp cloth or sponge only. Dry it with a soft cloth.

Do not use steel wool, acids or abrasive materials as they can damage the oven surface. Clean the oven control panel with the same precautions.

## **Cleaning the door gasket**

Regularly do a check of the door gasket. The door gasket is around the frame of the oven cavity. Do not use the oven if the door gasket is damaged. Contact an Authorised Service Centre.

To clean the door gasket, refer to the general information about cleaning.

## **Removing the shelf supports**

To clean the oven, remove the shelf supports.

## **⚠ CAUTION!**

Be careful when you remove the shelf supports.

1. Pull the front of the shelf support away from the side wall.

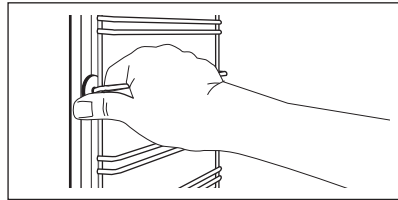

2. Pull the rear end of the shelf support away from the side wall and remove it.

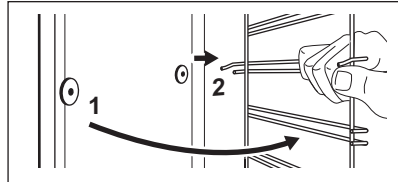

Install the removed accessories in the opposite sequence.

## **Removing and installing door**

The oven door has two glass panels. You can remove the oven door and the internal glass panel to clean it.



The oven door may close if you try to remove the internal glass panel before you remove the oven door.

## **⚠ CAUTION!**

Do not use the oven without the internal glass panel.

## CARE AND CLEANING

1. Open the door fully and hold both hinges.

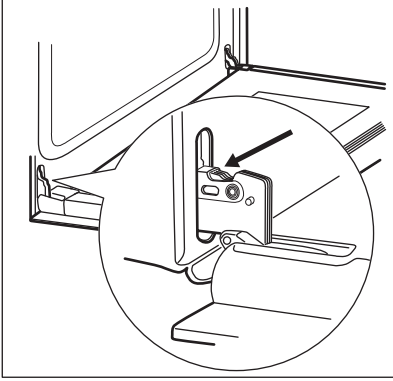

2. Lift and turn the levers on both hinges.

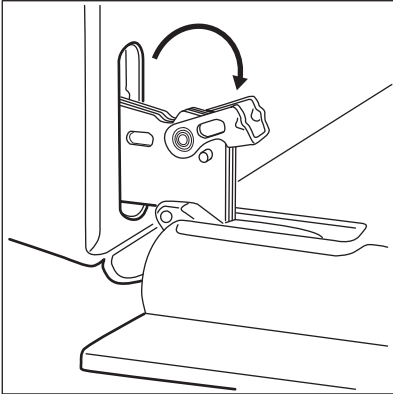

3. Close the oven door halfway to the first opening position. Then pull forward and remove the door from its seat.

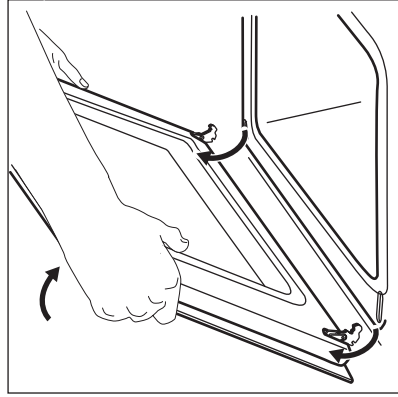

4. Put the door on a soft cloth on a stable surface.
5. Hold the door trim (B) on the top edge of the door at the two sides and push inwards to release the clip seal.

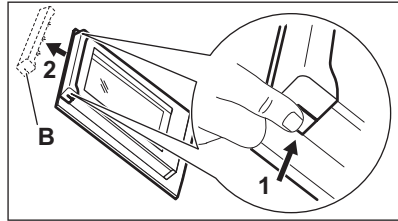

6. Pull the door trim to the front to remove it.
7. Hold the door glass panel by its top edge and carefully pull it out. Make sure the glass slides out of the supports completely.

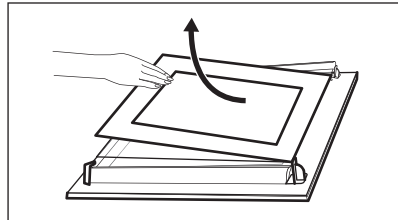

8. Clean the glass panel with water and soap. Dry the glass panel carefully. When the cleaning is completed, install the glass panel and the oven door. Do the above steps in the opposite sequence.

## CARE AND CLEANING

The screen-printing zone must face the inner side of the door. Make sure that after the installation the surface of the glass panel frame on the screen-printing zones is not rough when you touch it.

Make sure that you install the internal glass panel in the seats correctly.

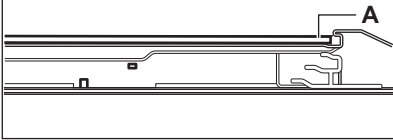

### Replacing the lamp

#### **⚠ WARNING!**

Risk of electric shock.  
The lamp can be hot.

1. Turn off the oven.  
Wait until the oven is cooled down.
2. Disconnect the oven from the mains.
3. Put a cloth on the bottom of the cavity.

#### **⚠ CAUTION!**

Always hold the halogen lamp with a cloth to prevent grease residue from burning on the lamp.

### The back lamp

1. Turn the lamp glass cover to remove it.
2. Clean the glass cover.
3. Replace the lamp with a suitable 300 °C heat-resistant lamp.
4. Install the glass cover.

## WARNING!

Refer to Safety chapters.

### What to do if...

PROBLEM	POSSIBLE CAUSE	REMEDY
The oven does not heat up.	The oven is off.	Turn on the oven.
The oven does not heat up.	The fuse is blown.	Make sure that the fuse is the cause of the malfunction. If the fuse problem recurs, contact a qualified electrician.
The oven does not work.	The automatic ignition does not work.	Light the burner with a long match. Hold the flame near the hole in the bottom of the oven cavity. At the same time push the knob for the gas control and turn it counterclockwise to the maximum temperature. When the flame lights, keep the knob for the gas control pushed for 15 seconds or less to warm up the thermocouple. Otherwise the gas flow is interrupted.
The lamp does not work.	The lamp is broken.	Replace the lamp.
Steam and condensation settle on the food and in the oven cavity.	A dish was left in the oven for too long.	Food should not be left in the oven for longer than 15-20 minutes after cooking.
The flame extinguishes immediately after ignition.	The thermocouple is not heated up.	After the flame lights, keep the knob for the gas control pushed for 15 seconds or less.
The turnspit does not rotate.	The turnspit is not correctly installed into the turnspit hole.	Refer to "Using the accessories" chapter, Using the turnspit.

### Service data

If you cannot find a solution to the problem yourself, contact your dealer or an Authorised Service Centre.

The necessary data for the service centre is on the rating plate. The rating plate is on the front frame of the oven cavity. Do not remove the rating plate from the oven cavity.

# TROUBLESHOOTING

## WE RECOMMEND THAT YOU WRITE THE DATA HERE:

Model (MOD.)	.....
Product number (PNC)	.....
Serial number (S.N.)	.....

## Technical data

TOTAL POWER:	Electric:	0.07 kW
	Gas original:	G30/G31 (3B/P) 50/50 mbar = 182 g/h
	Gas replacement:	-
Electric supply:	220 - 240 V ~ 50 - 60 Hz	
Appliance category:	I3B/P	
Gas connection:	G 1/2"	
Appliance class:	3	

## Gas oven burner

GAS TYPE	NOMINAL GAS POWER (KW)	NOMINAL GAS FLOW (G/H)	REDUCED GAS POWER (KW)	BY-PASS NEEDLE (1/100 MM)	INJECTOR MARK (1/100 MM)
G30/G31 (3B/P) 50/50 mbar	2.5	182	0.75	39	066

## Gas grill burner

GAS TYPE	NOMINAL GAS POWER (KW)	NOMINAL GAS FLOW (G/H)	REDUCED GAS POWER (KW)	BY-PASS NEEDLE (1/100 MM)	INJECTOR MARK (1/100 MM)
G30/G31 (3B/P) 50/50 mbar	1.75	127	-	-	53

## ENVIRONMENTAL CONCERNS

Recycle materials with the symbol . Put the packaging in relevant containers to recycle it. Help protect the environment and human health by recycling waste of electrical and electronic appliances. Do not

dispose of appliances marked with the symbol  with the household waste. Return the product to your local recycling facility or contact your municipal office.











867368753-A-382021